

New Milling Equipment for Versatile Uses

# VERTICAL RICE WHITENER

VTA12GM(2)-T / 15GM(2)-T / 20GM(2)-T



VTA12GM(2)-T



Satake innovates continuously and creates a marvel repeatedly. The new rice whitener is the latest in the list.

This machine improvises on existing design and incorporates various improvements to suit long grain milling in a gentle manner.

## FEATURES:

### 1. Gentle Milling :

The new design of VTA machine incorporates gentle milling of brown rice over a larger milling surface in the machine. This also ensures a greater whiteness per brake of VTA in a process.

### 2. Improved Bran Dissipation :

The inclusion of secondary air in the milling chamber ensures greater and much quicker removal of bran from the screens. This provides improved performance of screens in a continuous operation.

### 3. Lower Milling Temperatures :

Due to improved design for air circulation inside the milling chamber and greater aspiration through the bran duct, the temperature inside the milling chamber is greatly reduced. This retains the good characteristics of rice while it is milled gently.

### 4. Automation and Ease of Operation :

The new VTA design can apply optional features which enables this to integrate seamlessly with the plant automation providing a fully remote and automatic operation to the mill.

# VERTICAL RICE WHITENER

## Specifications

| Model                                     |               | VTA12GM(2)-T | VTA15GM(2)-T | VTA20GM(2)-T |
|---|---------------|--------------|--------------|--------------|
| Input Capacity (t/h)                      | Non-Parboiled | 5~6          | 6~8          | 8~10         |
|   | Parboiled     | 4~5          | 5~6          | 6~8          |
| Motor (kW)                                |               | 45~55(6P)    | 55~75(6P)    | 75~110(6P)   |
| Required Air Volume (m <sup>3</sup> /min) |               | 60~70        | 85~90        | 100~120      |
| Static Pressure (kpa)                     |               | 1.0~1.5      | 1.0~1.5      | 1.0~1.5      |

## Dimensions

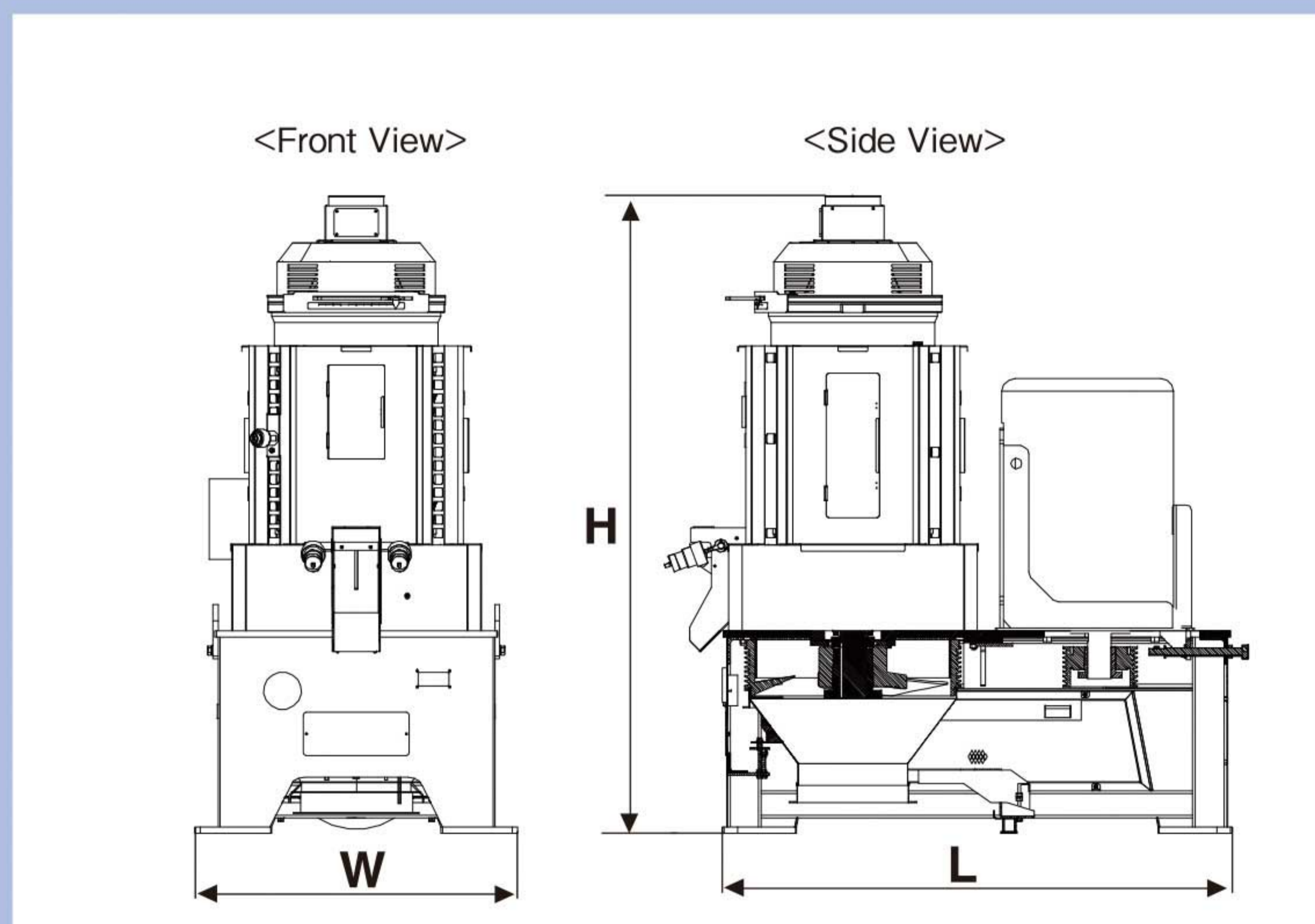

| Model        | W (mm) | L (mm) | H (mm) | Weight (kg)*1 |
|--------------|--------|--------|--------|---------------|
| VTA12GM(2)-T | 1,065  | 1,600  | 2,132  | 1,450         |
| VTA15GM(2)-T | 1,065  | 1,600  | 2,144  | 1,800         |
| VTA20GM(2)-T | 1,197  | 1,889  | 2,368  | 2,170         |

\*1 Approximate Net Weight (Without Motor)

All Satake products are the subject of continuous development and, as a result, their specification may change and differ in detail from those shown.

## SATAKE CORPORATION

Head Office  
2-30 Saijo Nishihonmachi,  
Higashi-Hiroshima-shi,  
Hiroshima-ken, 739-8602, Japan  
Tel : +81-82-420-8560/8539  
Fax : +81-82-420-0865  
URL : www.satake-japan.co.jp

SATAKE USA INC.  
10905 Cash Road,  
Stafford, Texas, 77477, U.S.A.  
Tel : +1-281-276-3600  
Fax : +1-281-494-1460  
URL : www.satake-usa.com

SATAKE (CANADA) INC.  
5100 Falingbrook Drive,  
Mississauga, Ontario, L5V 1S7,  
Canada  
Tel : +1-905-858-0791  
Fax : +1-905-858-0957  
e-mail : sales@satake-canada.com

SATAKE AMERICA LATINA LTDA.  
Rua Xavantes, 155-Pav. 20,  
Bairro Atiradores, CEP  
89203-210, Joinville, Santa  
Catarina, Brazil  
Tel : +55-47-3461-1313  
Fax : +55-47-3461-1300  
URL : www.satake.com.br/

SATAKE EUROPE LTD.  
P.O. Box 53, Horsfield Way,  
Bredbury Industrial Park, Bredbury,  
Stockport, Cheshire, SK6 2SU,  
U.K.  
Tel : +44-161-406-3800  
Fax : +44-161-406-3801  
URL : www.satake-europe.com

SATAKE INDIA ENGINEERING PVT. LTD.  
4th Floor, Tower-1, HB Twin  
Towers, A2, 3, 4, Netaji Subhash  
Place, Wazirpur District Centre,  
New Delhi, 110034, India  
Tel : +91-11-4706-2626  
Fax : +91-11-4706-2624  
URL : www.satakeindia.com/

SATAKE (THAILAND) CO., LTD.  
133,134 Moo 5, Bangkadi, Mueang  
Pathum Thani, Pathum Thani  
12000, Thailand  
Tel : +66-2-501-1180  
Fax : +66-2-501-1188  
URL : www.sataketh.com:8080/

SATAKE INTERNATIONAL BANGKOK CO., LTD.  
888/84 Mahatun Plaza Bld., 8th  
Floor, Ploenchit Rd., Lumpini,  
Pathumwan, Bangkok, 10330,  
Thailand  
Tel : +66-2-651-5845  
Fax : +66-2-651-5848  
URL : www.sataketh.com:8080/

SATAKE MANUFACTURING (SUZHOU) CO., LTD.  
229 Jin Feng Road, Suzhou New  
District, Suzhou, Jiangsu Province,  
215129, China  
Tel : +86-512-6536-8225  
Fax : +86-512-6536-5922  
URL : www.satake.cn/

SATAKE AUSTRALIA PTY. LTD.  
15 Leland Street, Penrith, N.S.W.,  
2750, Australia  
Tel : +61-2-4725-2600  
Fax : +61-2-4725-2601  
URL : www.satake.com.au

SATAKE CORPORATION has  
obtained ISO 9001 and ISO  
14001 certification.  
These international standards  
for management systems  
ensure Satake will continue to  
provide high quality products  
and services.

ISO 9001 Certification  
(Quality Management Systems)

ISO 14001 Certification  
(Environmental Management Systems)